

Supplemental Guidelines for Type CS2 Pavilions

(Guides and points to note for designing exhibitions)

1. Locations (plots allocated to countries) CS2
2. Reference marking
3. Points to note for exhibition design and implementation (floors, walls, and columns)
※column = pillar, in the guidelines
4. Floors and walls
5. Underfloor pits and distribution board position plans
6. Lighting positions
7. Points to note for exhibition design and implementation (ceilings, utilities and temporary works related to construction)
8. Hanging points
9. Points to note for exhibition design and implementation (other)
10. Separated space within the exhibition plot (compact auditorium etc.)
11. Mezzanine (intermediate floor)
12. Facade design and country name signboard

In the future, an Interior Supervision Office (tentative name) will be set up in the OSS (One Stop Shop) to provide support to all official participants in the design and construction of the exhibition interior (interior exhibition, fire safety permits and authorisations, construction process, management of vehicles entering and leaving the sites, etc.).

November 2023

1. Locations (plots allocated to countries) CS2

Exhibition area

- The exhibition plot (E78-E88) allocated to each country has a floor area of 53 m². The maximum height of the exhibition is up to 4,500 mm.
- The exhibition plot E88 is in an island configuration. Plot walls need to be installed to partition from the adjacent commercial spaces on either side. The maximum height of the exhibition is up to 4,500 mm.
- Seek advice from the Interior Supervising Office regarding the heights of features hang from the roof structures, such as banners. When implementing the exhibition work, pay due attention to the lighting cable ducts installed above the exhibition plots.
- Structural columns (150 mm square) are distributed inside the building. Each column is positioned as shown in the plan below.

Commercial space

- The commercial spaces are demarcated on the floor in white lines. There are no partition walls.
- If a restaurant with a kitchen is to be organised, please consult the *Pavilion Handbook and considerations for designing a restaurant kitchen* which was issued separately. Please also consult the Interior Supervising Office without delay.

Plot layout

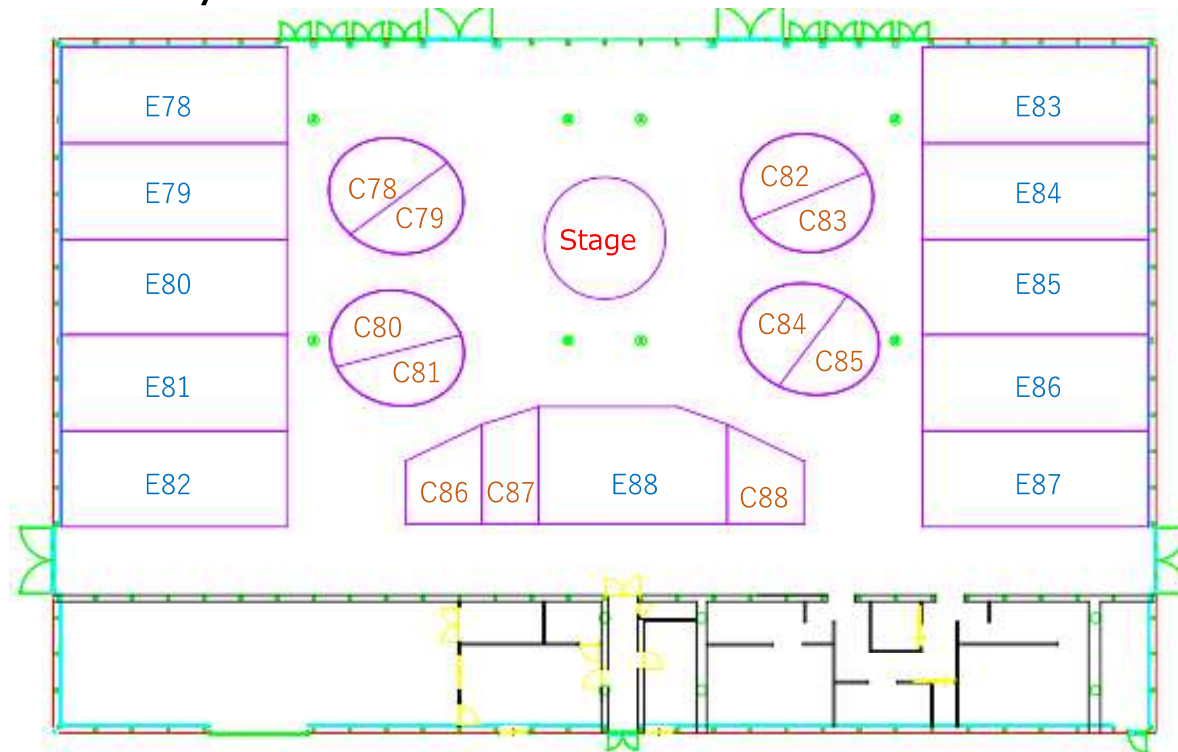

Column position plan

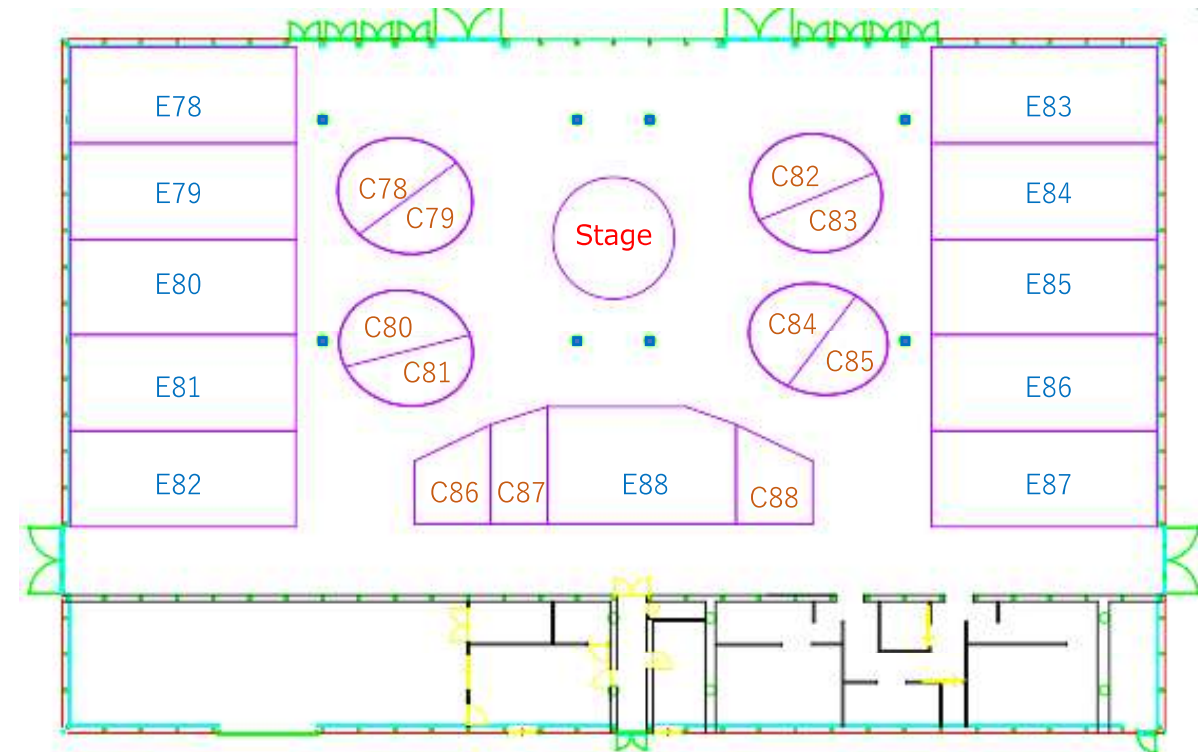

2. Reference marking

Reference marking

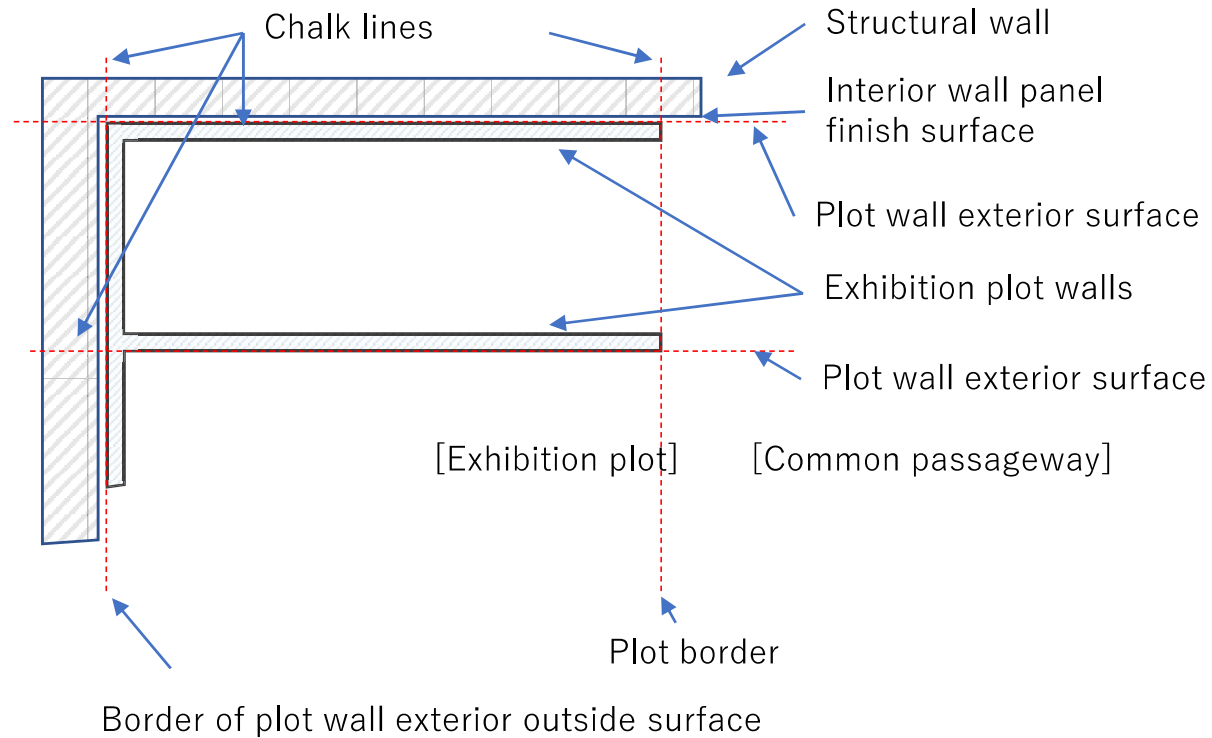

The standard layout (reference marking) of the exhibition plots prepared by the countries and the standard section details of the plot wall are as illustrated.

- Install plot walls inside the plot border lines.
- Install the plot back walls against the interior wall panels.
- The plot walls must be covered with white cloth or other cosmetic materials on the rear side, except those surfaces facing the structural wall, leaving no wall structural elements exposed.
- As for the walls shared between adjacent plots (participating countries), the parties shall need to discuss their arrangements in advance and consult the Interior Supervising Office.

3. Points to note for exhibition design and implementation (floors, walls, and columns)



Floors

- The floor is trowel-finished on mortar at the time of plot handover. If the exhibit (including its pedestal) has a footprint of which one edge is shorter than the exhibit height (including its pedestal) or the centre of gravity higher than 50% of the height, and therefore is instable, it is strongly recommended that it is anchored to the floor.
- When installing anchoring devices, ensure at least 200 mm of margin from the edge of the floating foundation core. Also, at least 150 mm of margin must be reserved from the edges of duct access chambers. Exercise due care when implementing the work so as not to cut the rebar inside the slab.
- The load capacity of the floor is 9.8 kN/m² (approx. 1 t/m²).
- Raising the floor within the exhibition plot for the area accessible to general visitors, if it is raised more than 160 mm, requires an installation of at least two steps in accordance with the universal design guidelines. It is also necessary, according to the universal design guidelines, to provide an additional slope. A slope is still required to install when the floor is raised by less than 160 mm.
- If the floor has a level difference of no more than 30 mm, a bevelled edge must be installed to prevent tripping.
- If the floor surfaces should be modified (including painting), ensure to use slip resistant materials.

Walls

- The plots are set out with plot border marking at the time of handover. Participants shall install walls inside the setting-out lines according to the aforementioned reference marking.
- Regarding the drop/fall prevention measures of exhibits, pedestals, furniture, and appliances, the corner buffering to alleviate the physical damage to general visitors by crushing into, the precautions for installing glass members, etc., consult the *Points to observe when designing and implementing interior exhibitions* to be issued separately.

Columns

- Even if structural columns (150 mm square) are located near the exhibition plot which is handed over in the common passageway, these columns may not be used or modified.

4. Floors and walls

Floating foundation core position plan

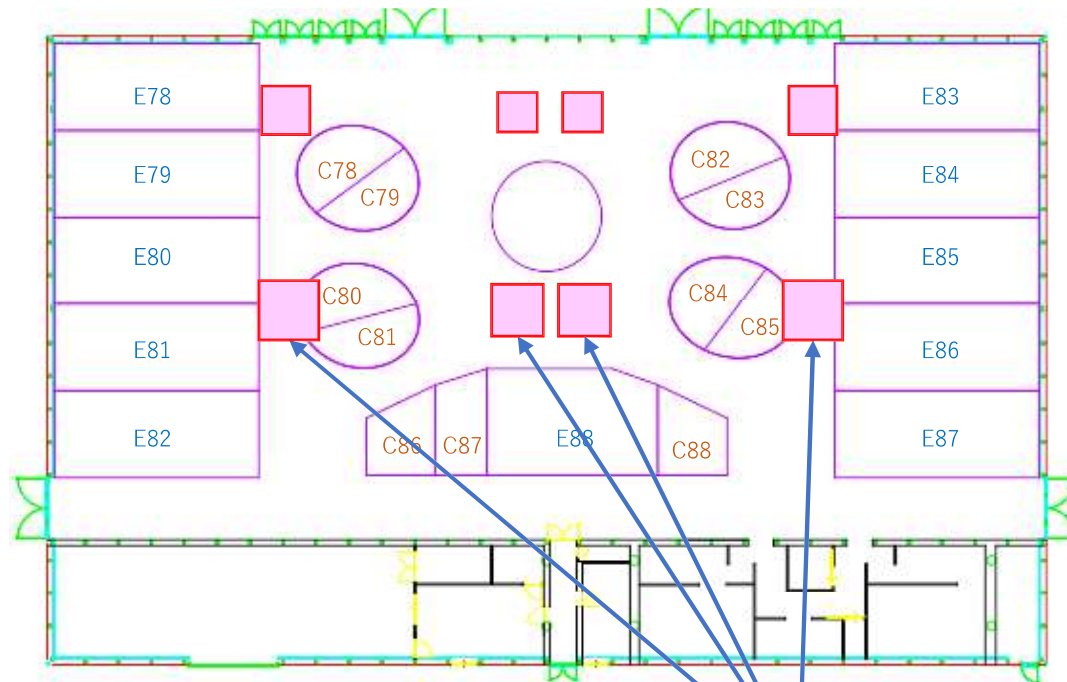

Floating foundation cores
No anchoring

Pin type anchor bolt,
max. 16 mm dia. and 60 mm in depth

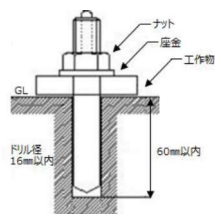

Floor concrete
 $t = 200 \text{ mm}$

Load capacity
 9.8 kN/m^2

Post and lintel: $9,000 \text{ N/m}^2$
Seismic force: $5,900 \text{ N/m}^2$

Work that involves anchoring shall require the Organiser's approval upon submission of relevant detail drawings. Ensure a minimum of 200 mm margin from the edge of a floating foundation core. Exercise due care during the installation work so as not to cut into the wire mesh. Ensure a minimum of 150 mm margin from the edges of duct access chambers.

Sectional detail

Decorative structure on the external wall

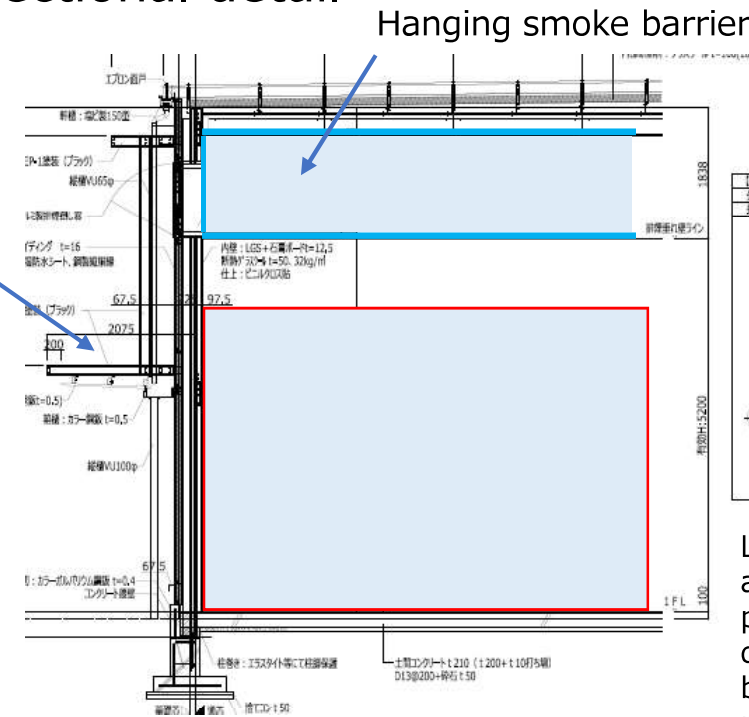

Hanging smoke barrier

Sectional detail of internal wall

Interior wall panel

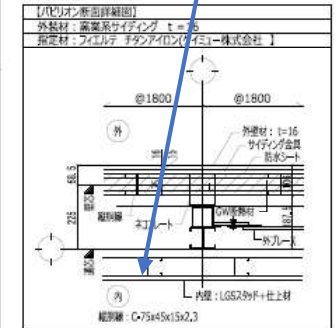

Light weight objects, such as framed pictures and poster panels, may be directly mounted on the building's interior wall panels.

Heavy items, such as monitors and sound system equipment, may not be mounted directly. To mount heavy items, conduct an on-site verification of the positions of base structural members (which are evenly distributed), which can hold screws, add supporting base, and secure the mounted items.

- The maximum height for participants' exhibition staging is H: 4,500 mm from the floor slab.
- If walls are installed between adjacent plots, ensure that the rear side of the walls are also covered. Walls with exhibition systems, if installed, must also be covered the entire surface of the rear side with white cloth or the like.
- If a mezzanine is arranged to be accessible to visitors, this must be designed according to the UD Guideline.

5. Underfloor pits and distribution board position plans

Electricity

- The arrangement of pits for a CS2 building is as illustrated below. They run adjacent to all exhibition plots, and distribution boards are arranged in each plot drawing from the chambers. Participants shall arrange the wiring and electrical installation work within their exhibition spaces to be fed from their distribution boards. Distribution boards are also provided in each commercial space. Ensure that your power plan respect the maximum capacity allocated to each of the exhibition and commercial spaces.

Pits

- As for the water and sewage piping, the water line is fitted with a valve, and the sewage line is capped, both inside the trench of a CS2 building.
- The covers of the pit have the load capacity of 9,800 N/m², like the floor. Refrain from installing exhibits in such a way that their load is localised in one point. If transport vehicles, aerial work platforms, or other vehicles enter the building, take appropriate measures of protection in advance.
- The load capacity of the inspection hole cover on the trench is 4,900 N/m². No vehicles are allowed to drive on the inspection hole covers.

Pits and trenches plan

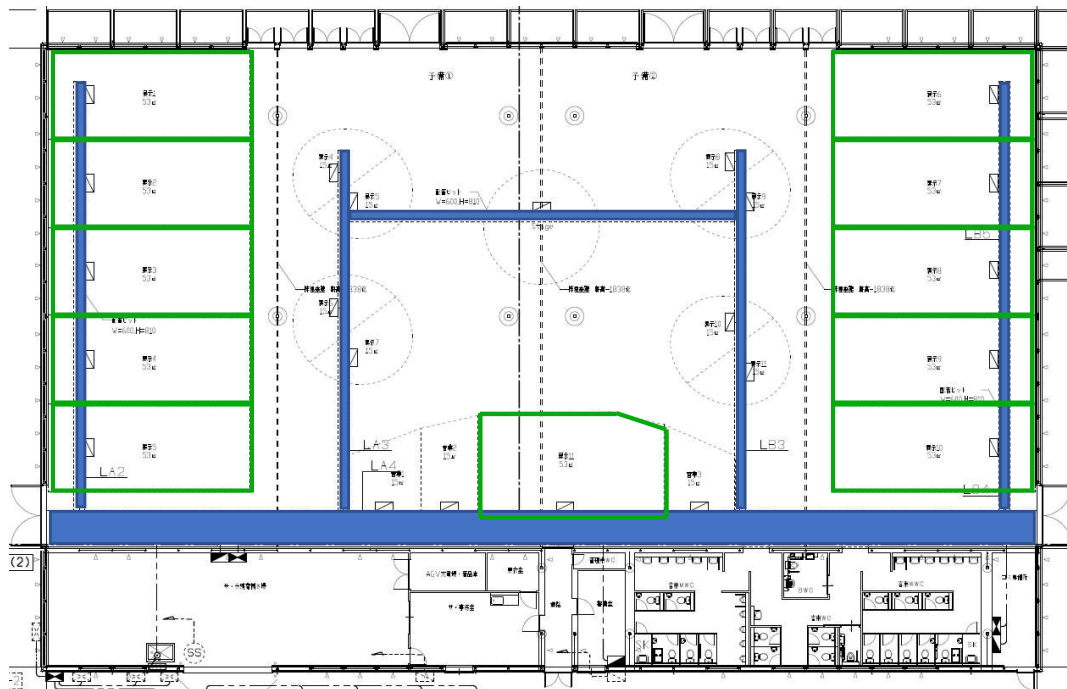

Distribution board position plan

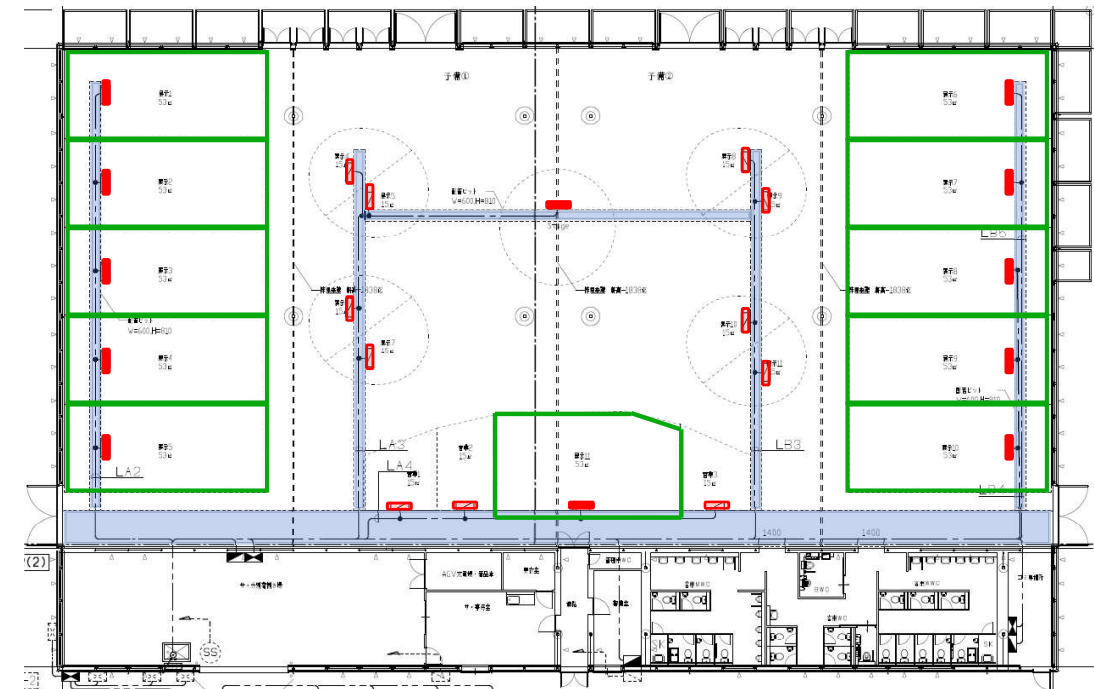

6. Lighting positions

The positions of the lighting appliances in an exhibition space are as illustrated below.

- Lighting cable duct is installed at FL+5,000 mm.
- The cable ducts in the exhibition space comprise five 54 m ducts and ten 27 m ducts, forming two systems on either side of the pavilion divided in the middle, and one system reserved for BOH.
- Additional lighting equipment or other appliances may not be connected to the lighting cable ducts.

- Participating countries (exhibit installation contractors) shall be responsible for adjusting the lighting equipment orientation. During installation work, it is prohibited to move the lighting appliances over to another electrical system or add lighting appliances etc. other than those originally provided.
- Where the external lighting equipment needs changing the beam angles, this shall be conducted by the contractors for common work concerning pavilion exhibit installation.

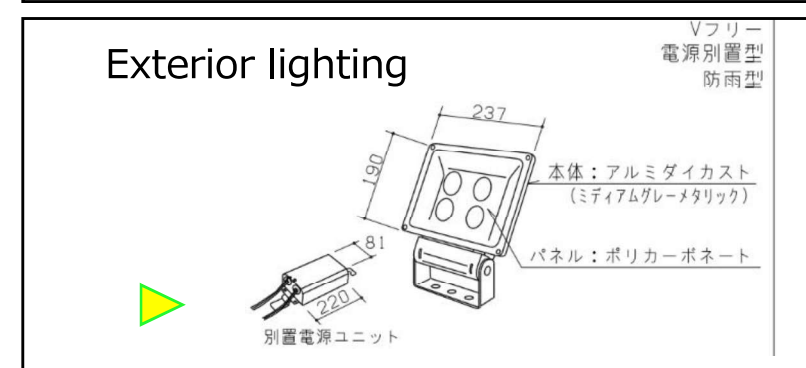
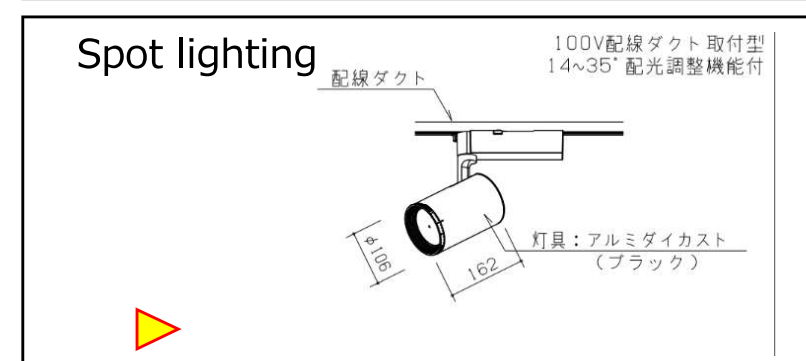
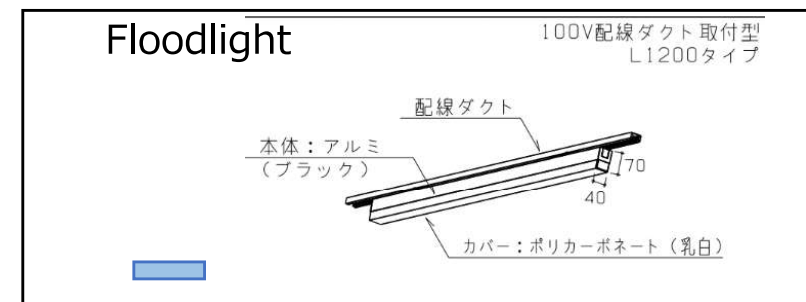
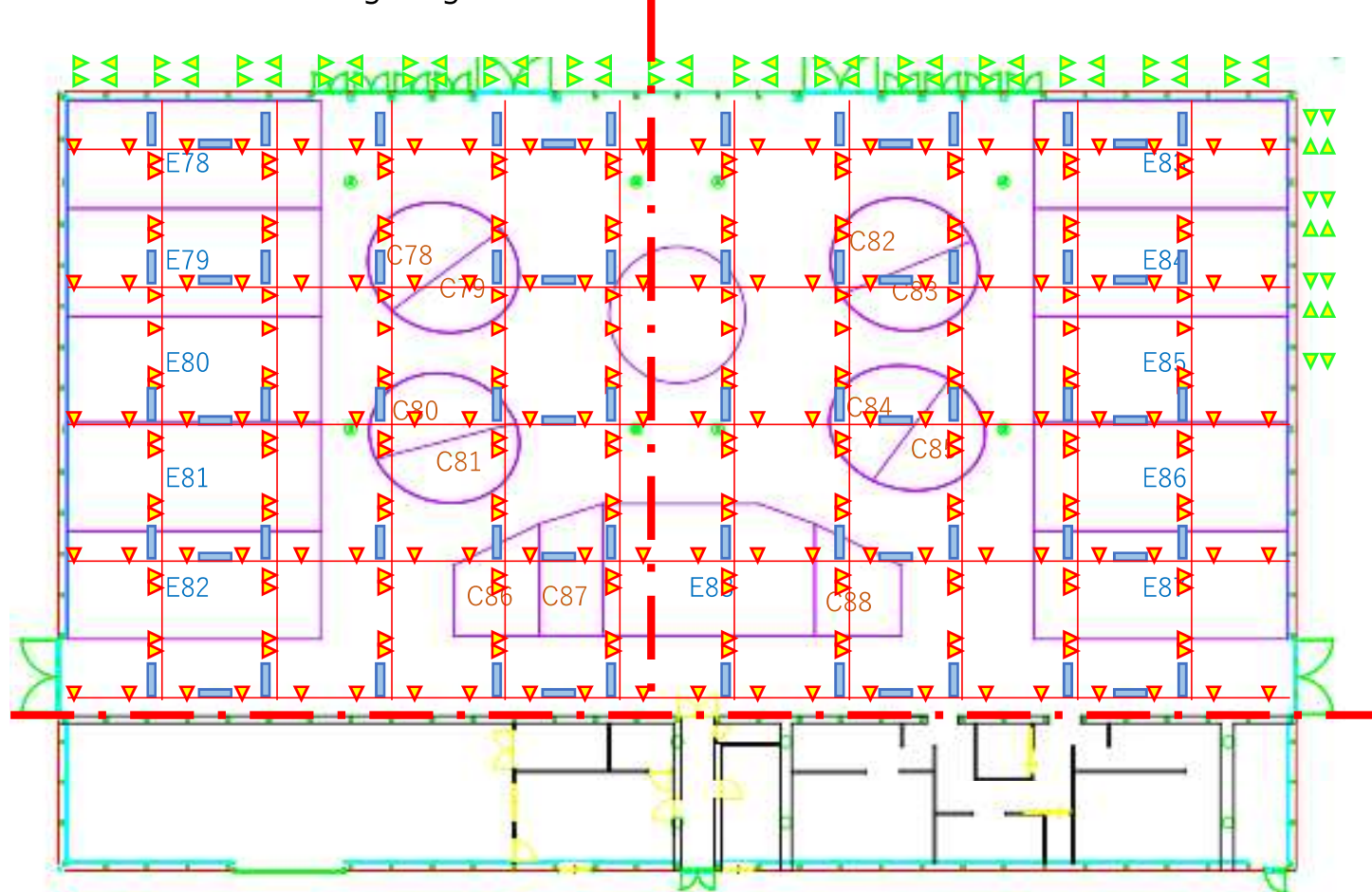

7. Points to note for exhibition design and implementation (ceilings, utilities, and temporary works related to construction)



Ceilings

- The ceilings in a CS2 building are bare ceilings. For planning exhibits to be suspended over the exhibition plot, secure the suspension points on the I-beam rafters. Note that the maximum suspension load is 200 N/m².
- As for the suspension points to be reserved, a banner requires two points, and other structures require at least three points, with clamps fastened with bolts obligatory as a fall-preventive measure.
- Smoke barriers are suspended from the roof down to the height of FL+5,200 mm. Lighting cable duct rails for the interior floodlights/spot lights are installed at a lower height (FL+5,000) to avoid the smoke barriers. The maximum height for exhibits (FL+4,500) must be strictly observed.
- Consult the Interior Supervising Office (tentative name) if display decorations (fabrics, curtains, objects, etc.) surpass the maximum exhibit height (FL+4,500). Ensure that these are designed to avoid interfering with the smoke venting equipment (smoke vents), smoke barriers, emergency light equipment, evacuation guide light equipment, and other safety equipment installed by the Organiser.
- It is prohibited to appropriate electric power from the floodlight cable duct rails.
- Consult the Interior Supervision Office (tentative name) when removing the existing lighting equipment installed along the floodlight cable ducts. Relocating or changing the beam angle shall be made by the participating country (exhibition contractor).

Utilities

- Each of exhibition and commercial plots is equipped with a distribution board connected to the nearest duct rails.
- The installation of electric equipment must be carried out by qualified electricians. Wiring within the commercial plots must be installed in the duct access chambers and avoid wherever possible wiring on the floor. Where cable installation on the floor surface is inevitable, apply floor cord covers to prevent risks of tripping and cable severance, bearing in mind the universal design requirements.
 - Ensure that the materials and cables used in the electric work meet the required standards with reference to the equipment to be used. Use of combine ducts (CDs or conduits) is mandatory in the wiring work. Never leave cabled exposed.
 - Always employ engineers with Type 1 Electrical Work Engineer Certification issued in Japan or higher qualifications to implement the installation work.
 - Where the exhibits include neon tube lights, the engineer must be qualified for Special Electrical Work Engineer Certification (for neon installation).
- The water and sewage piping is installed up to the trench, and both lines are plugged. Plumbing within the exhibition and commercial plots shall be drawn from the duct access chambers as necessary.

Temporary works related to construction

- When implementing work in the exhibition plots, the participants shall be responsible to plan temporary works related to construction, including areas for material delivery, sorting, and storing, smoking area, and workers' station, ensuring smooth implementation of exhibit installation in co-ordination with other participants.
- Conducting work, including unloading, outside pavilion plots requires notification to the Communication and Coordination Council (CCC) for coordination. For detail, refer to the 'Upon determining contractors' through the link provided in the Official Participants Portal.

8. Hanging points

The participating countries allocated in CS2 buildings may install exhibits or other items on the ceiling within the projected area above their respective exhibition spaces as shown below.

■ Ceiling

- Hanging points may be attached to structural members (I-beam rafters) of the ceiling.
- Cable duct rails run at H: 5,000, below smoke barriers. Exercise due attention when conducting aerial work.
- The maximum height accessible for exhibition and staging is H: 4,500 mm.

Reflected ceiling plan

Areas where suspension from the ceiling is permitted (marked in pink)

Suspension load capacity on the ceiling 200 N/m²

Smoke barriers (blue lines)

Sectional detail

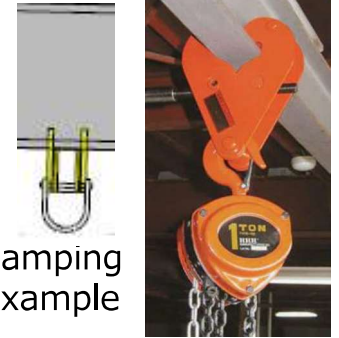
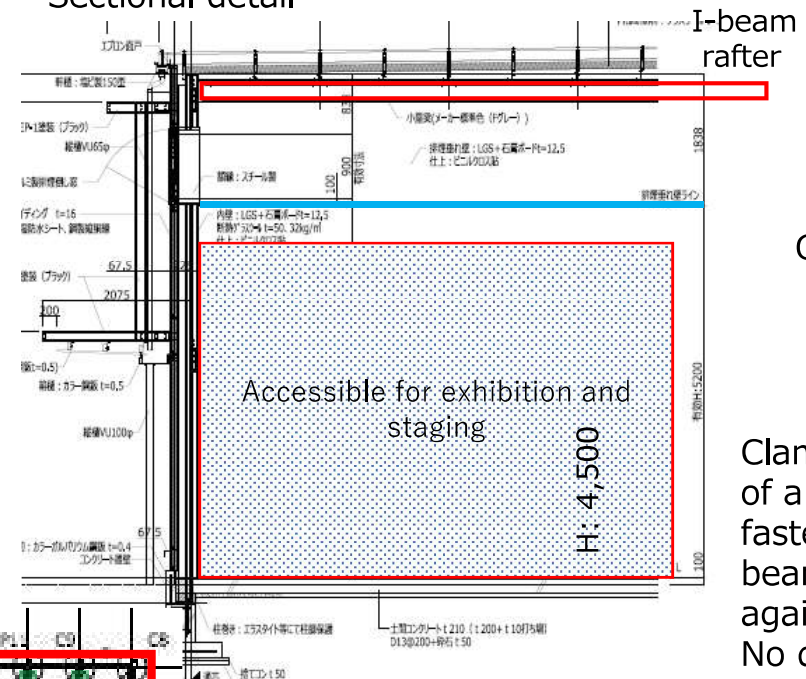
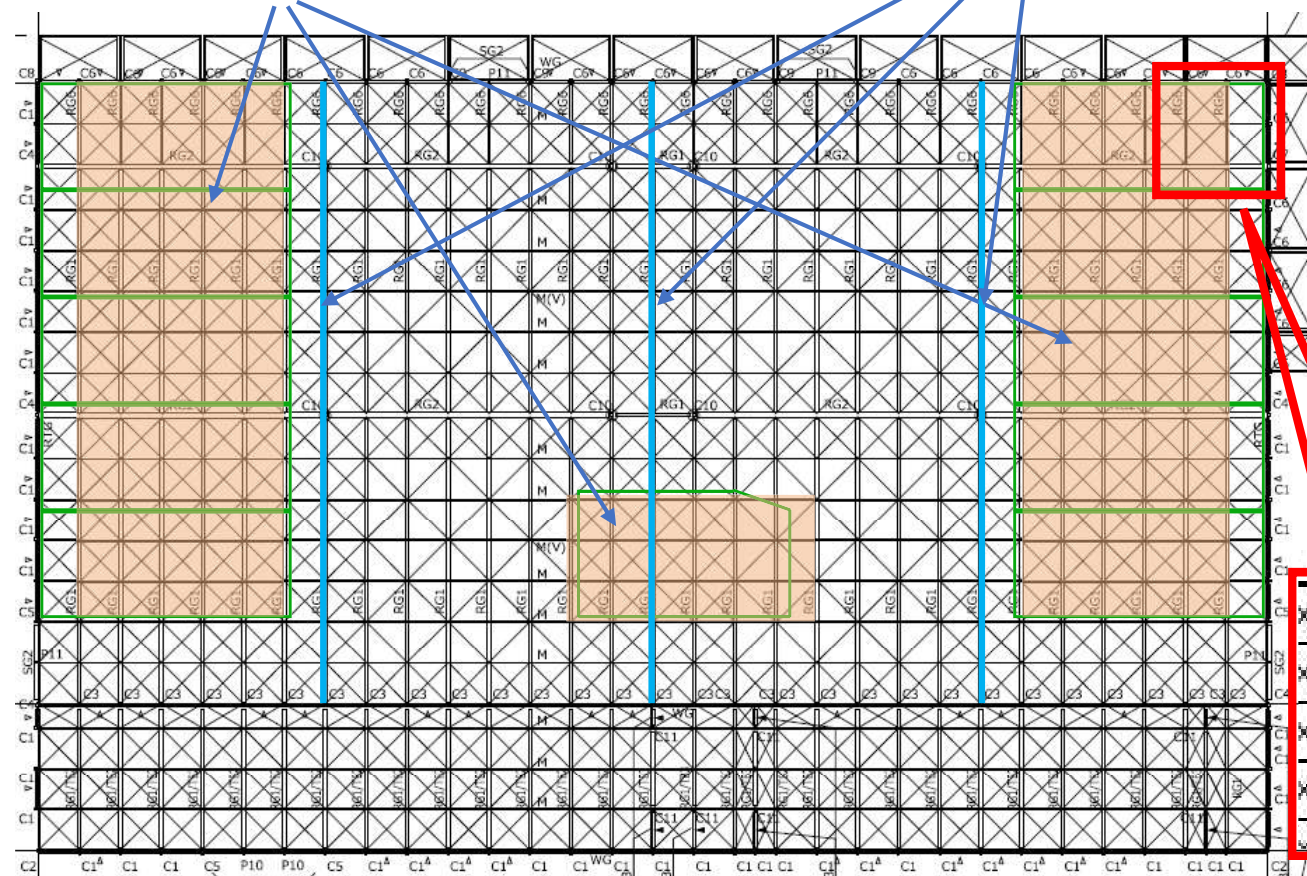

Clamping example

Clamp on the bottom edge of I-beam

Clamps: use a combination of a bracket and bolt fastening to clamp on the beam structure, secured against dropping accidents. No drilling or welding on the beam allowed.

Distribute the load to avoid excessive localised load.

Hanging points may be mounted on the beams highlighted in green



9. Points to note for exhibition design and implementation (other)

(1) Staging light

- Staging lights may not be projected outside the allocated exhibition plot. This, however, does not apply to upward projection onto the ceiling above the exhibition plot.
- Use of laser beams may be subject to various legal regulations depending on the output power. Please consult the Interior Supervising Office (tentative name) in advance.

(2) Sound system

- The noise levels from the exhibition plots must be kept under 65 dB.
- It is prohibited to direct speakers or other amplification apparatus towards neighbouring booths. Ensure that these are positioned inwards than towards the front from the stage. Speakers mounted on a wall or non-structural post must be directed so that the angle of its centre line to the line perpendicular to the floor is no more than 45 degrees.

(3) Scent (odour)

- If odour is produced from the exhibition plot, measures such as deodoriser equipment must be put in place to prevent its diffusion into other exhibition plots.

(4) Prohibition of the use of the space outside allocated exhibition area and commercial spaces

- Exhibits may not be installed outside the allocated exhibition plot.
- Where visual lighting projection is planned to extend into the common passageway in front of the exhibition plot, this is only permitted onto the floor within 2 m of the allocated exhibition plot border. However, the floor surface may not be modified for the purpose of said projection.
- It is not permitted to plan to use the common passageway for viewing the exhibition, causing visitors to loiter.
- The installation of visual systems and stage or similar arrangements must be planned in such a way that visitors are accommodated in the allocated exhibition plot for viewing.

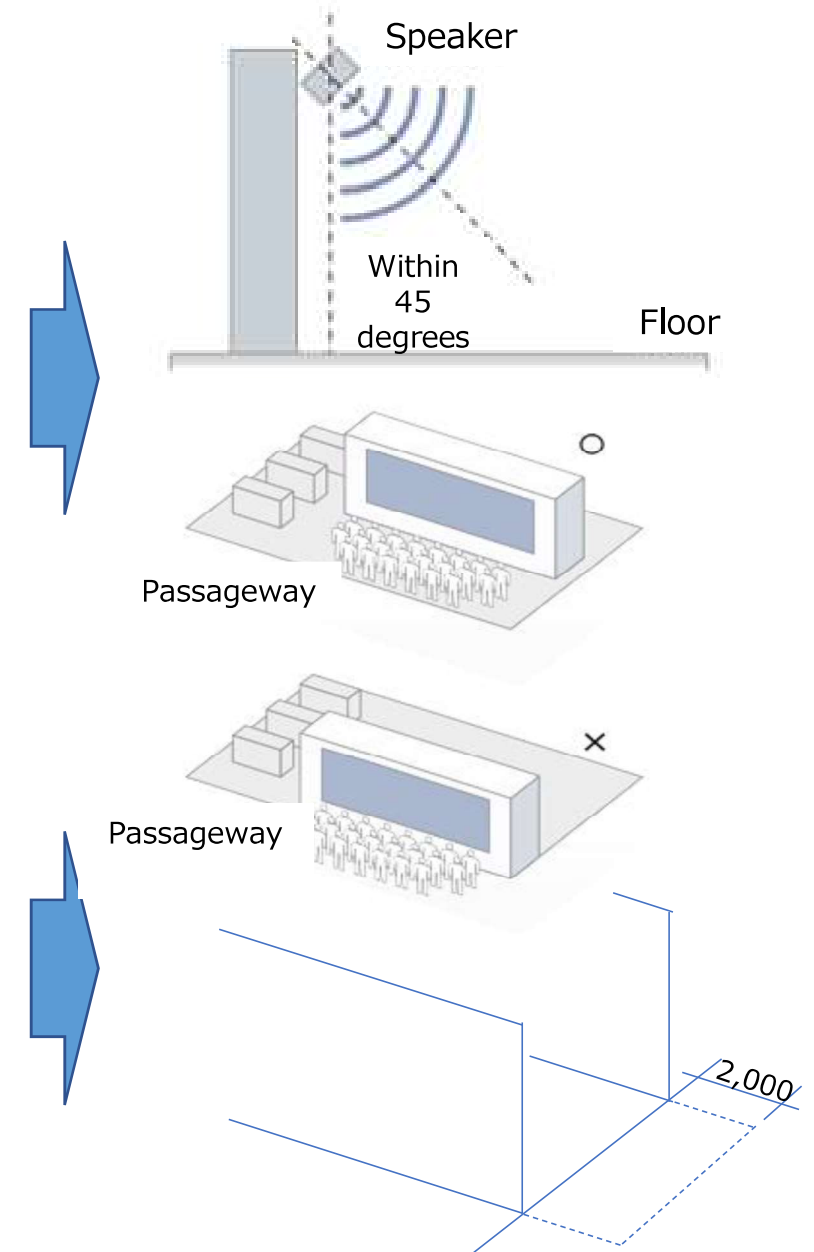

10. Separated space within the exhibition plot (compact auditorium etc.)

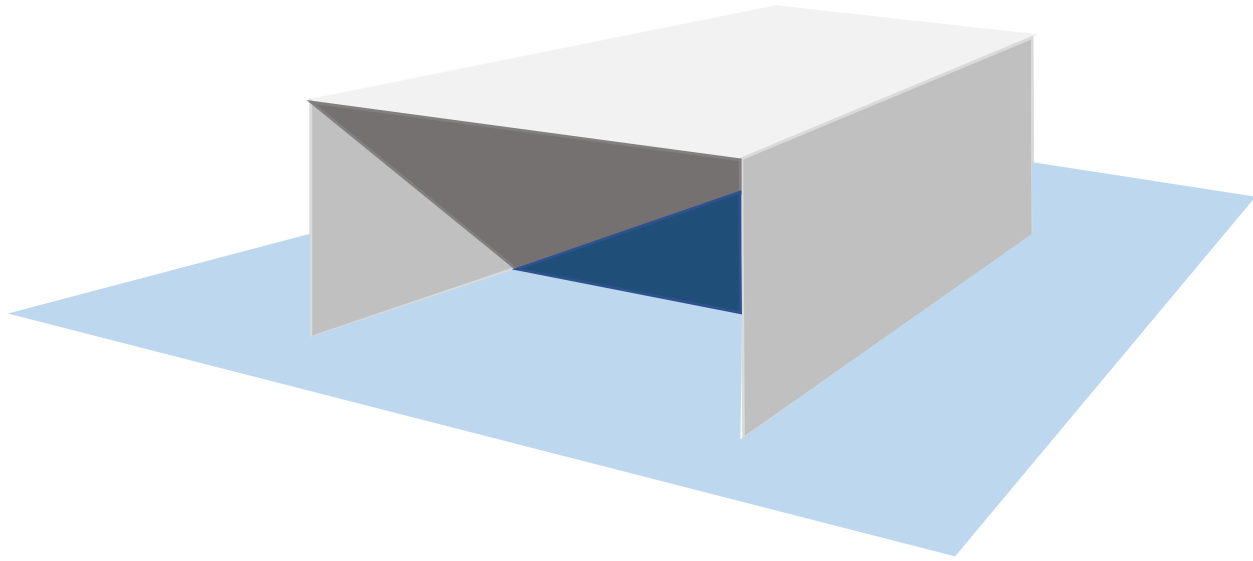

- Ensure an opening of minimum 2,000 wide and 2,100 high in the front of the exhibition plot.
- Where a room (a space partitioned with a floor, ceiling, and walls) such as a compact auditorium is to be implemented within an exhibition plot, not all walls and the ceiling can be covered altogether. At least one side needs to be open (no smaller than 1/6 of the exhibition plot area size). The ceiling must be designed with mesh materials or otherwise structured so that smoke does not get trapped inside the room.
- Evacuation safety equipment required pursuant to the provisions of the Fire Service Act may need to be added or relocated. It is recommended to consult the Interior Supervising Office (tentative name) at an earlier opportunity.

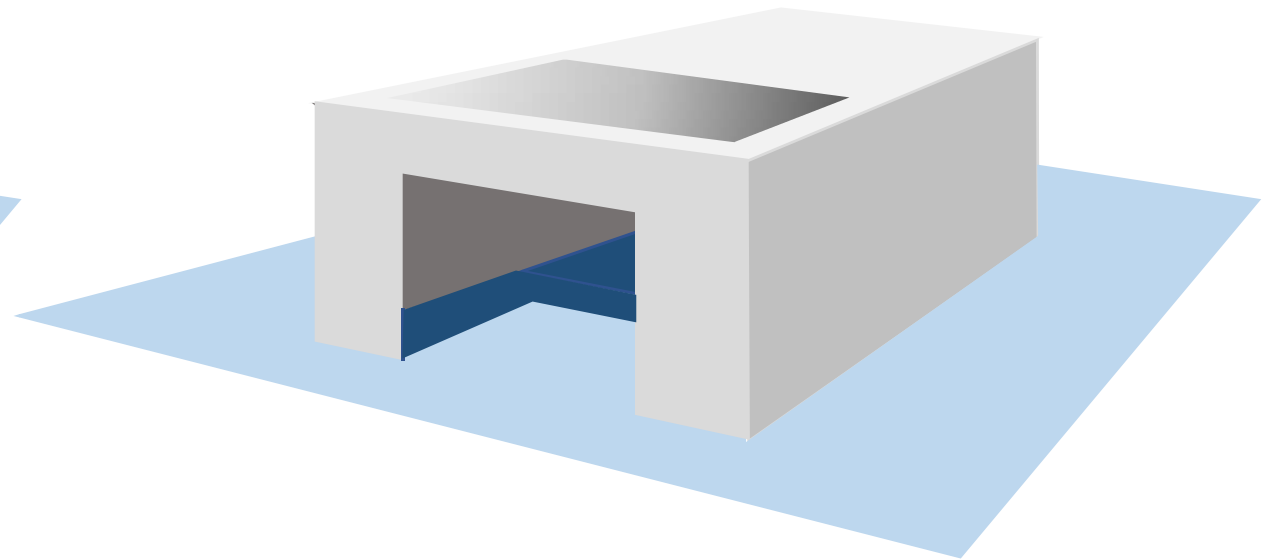
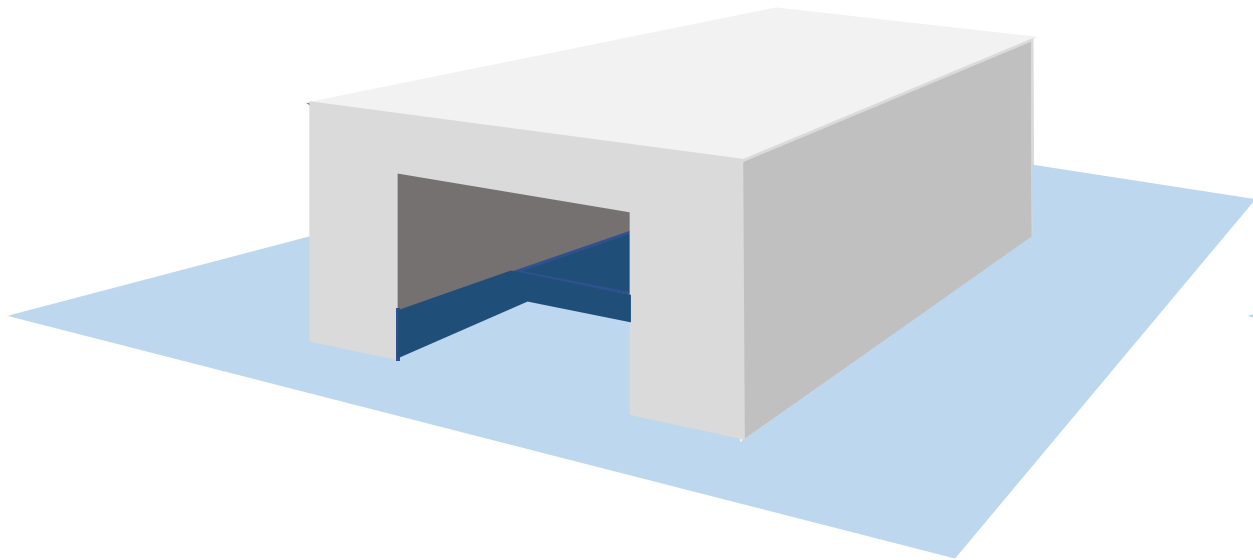

11. Mezzanine (intermediate floor)

- It is possible to arrange a mezzanine in a CS2 building (up to 50% of the exhibition space floor area). As this will require an application for modifying the building permit, please notify the Interior Supervising Office at your earliest opportunity.
- Adding a mezzanine does not change the maximum exhibition height, which must be strictly observed.
- Additional evacuation safety navigation equipment will be required pursuant to the provisions of the Fire Service Act.
- If the mezzanine is made accessible to general visitors, it must comply with the Universal Design Guideline. This does not apply if it is only accessible to the participant's officials.

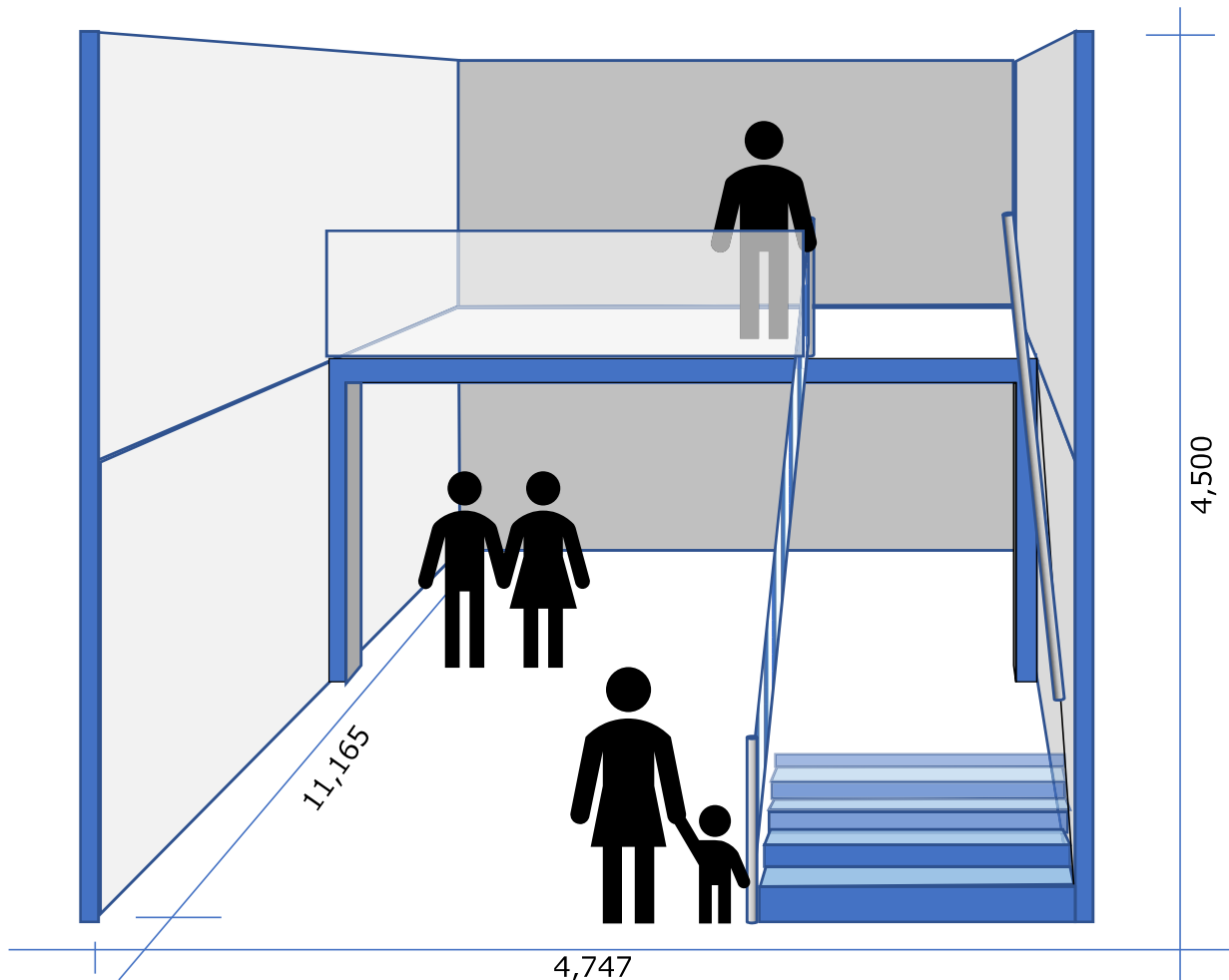

12. Facade design and country name signboard

[Facade design] Staggered layout on a plane

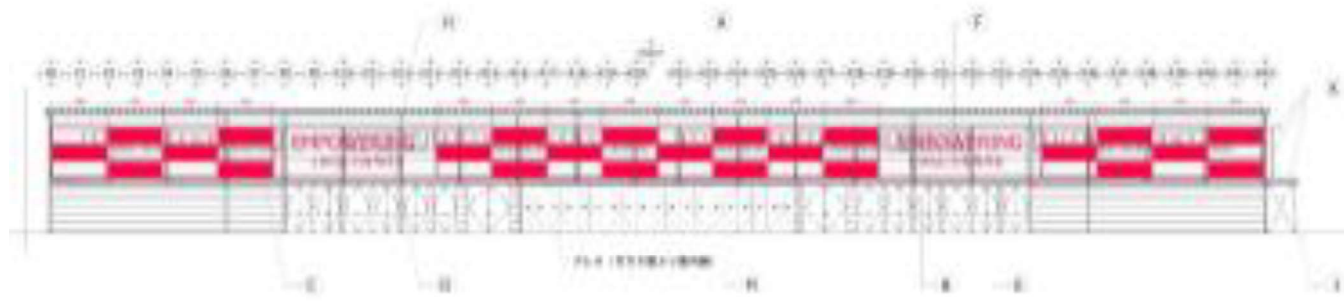

[Country name signboard]

Under Construction
Pavilion signboard approach to designs, sample designs, installation methods
Country name signboard, approach to designs, sample designs, installation methods